

OMEGA S/S KEY SWITCH

LARGE FRONT PANEL

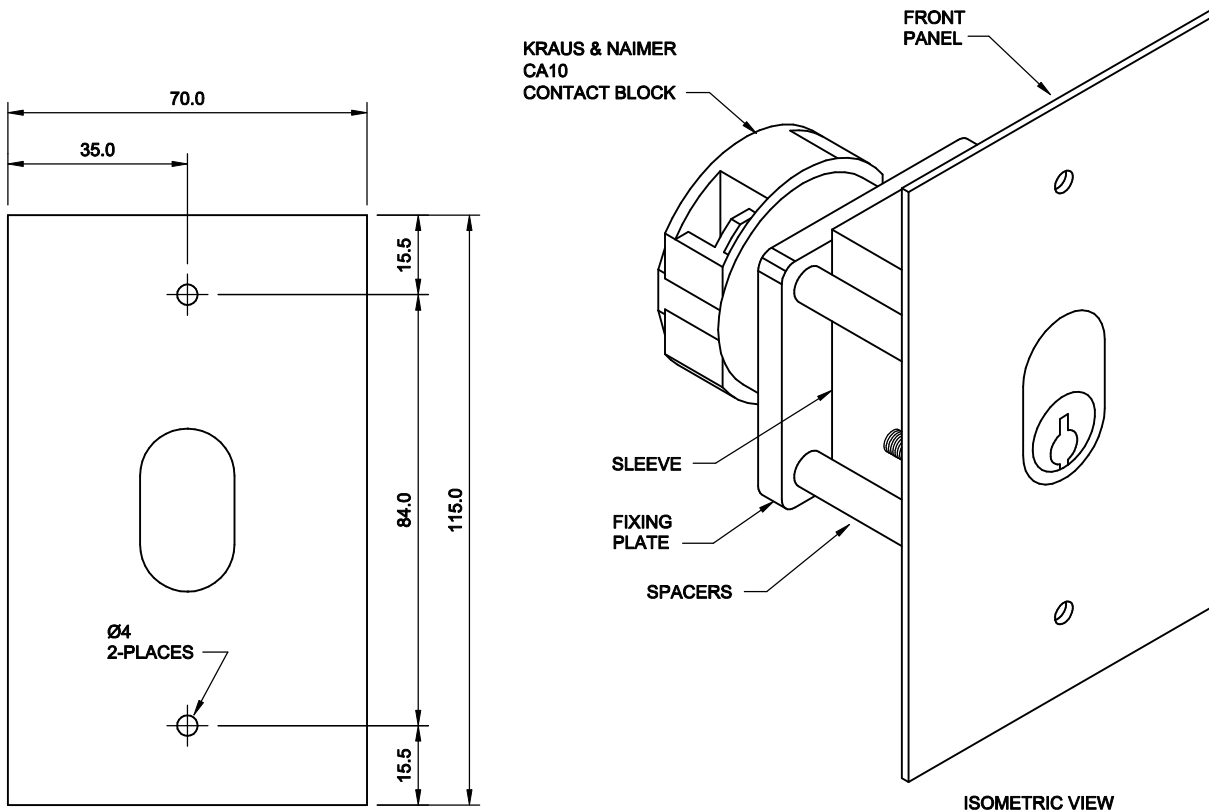
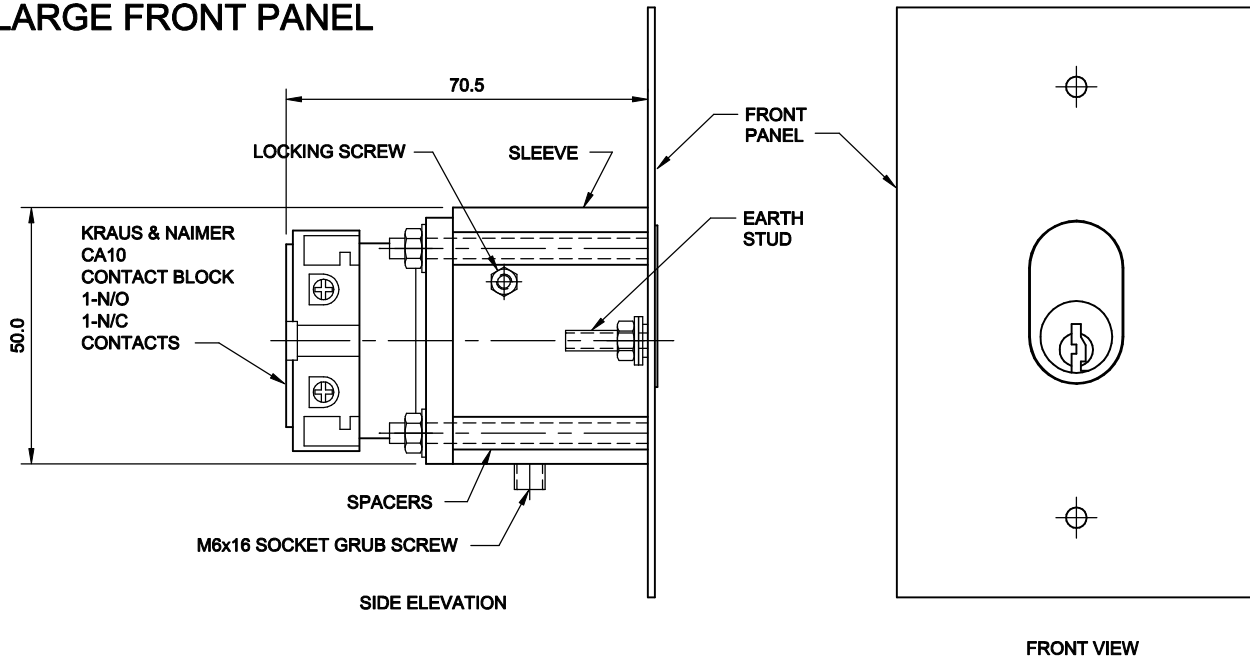

PANEL HOLE DETAILS

GENERAL TECHNICAL INFORMATION:
 DO NOT LUBRICATE OR TREAT CONTACTS IN ANY WAY.
 USE COPPER WIRE ONLY.
 TAKE CARE DURING INSTALLATION TO ENSURE FACTORY
 FITTED JUMPER LINKS ARE NOT LOST BY UNDOING
 BOTH SIDES OF LINK.
 AFTER WIRING, ALL TERMINAL SCREWS MUST BE
 TIGHTENED WITH 0.60 Nm TORQUE.

VOLTAGE AND CURRENT RATINGS		
	VOLTAGE (V)	CURRENT (A)
AC	220-240	5
AC	380-440	4



Security Controls Pty Ltd

256 Hyde Street, Yarraville Vic. 3013
 Tel.+61 3 9689 3488 Fax.(03) 9687 5139
 email: cmacmillan@omegacorp.com.au